

Impact-E 380



Features

The Impact-E 380 is a compact, low power embedded system, utilising Intel® 8th and 9th Generation mobile iCore™ processing technology. This achieves high processing power with minimal power draw.

Key features:-

- Low power consumption
- High end processing power
- 3 Slot expansion system
- 3 year warranty
- 15 Year life cycle

Dimensions

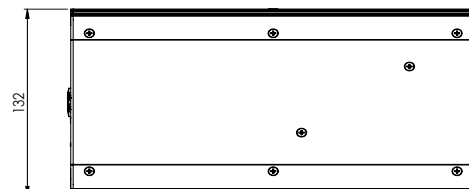
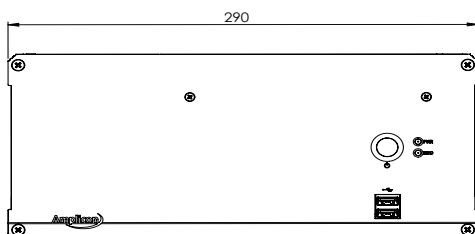
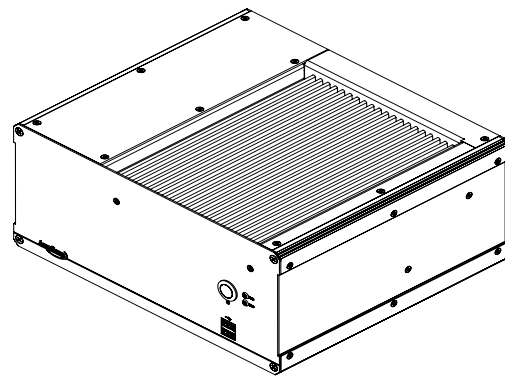
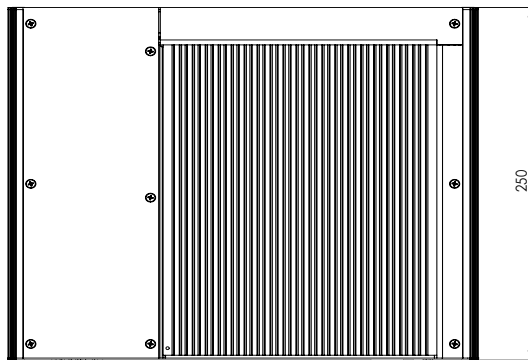

Impact-E 380

The information is believed to be accurate. However Amplicon Liveline Limited accepts no responsibility for any problems caused by errors and omissions. Specifications are subject to change without notice.

Specifications

Hardware specifications	CPU: 8th Generation Intel® Core™ Processors, LGA 1151 Socket, TDP up to 35W 9th Generation Intel® Core™ Processors, LGA 1151 Socket, TDP up to 35W Main memory: 4GB SODIMM DDR4 (max: 32GB 2666MHz MHz) Chipset: Intel® Q370 LAN: Dual integrated 10/100/1000 network connection.	Main board power options	Supports DC input voltage +9-36VDC
BIOS	AMI	Mechanical	Design: Rugged compact embedded design Cooling: Fanless design Construction: Extruded Aluminium Colour: Black Dimension: 290 x 132 x 250mm (W x H x D) Gross Weight: 3.6kg
Display	DP1.2: resolution up to 4096x2304 @ 60Hz	Environmental operation	Acoustic noise: Near silent operation Operating Temperature: 0°C to 55°C Humidity: 0 to 90% non-condensing
Storage	2 x 2.5" SSD/HDD Support for RAID 0 and 1	Environmental storage	Temperature: -20°C to 70°C Humidity : 5% to 90% @ 20°C
System expansion	1 x PCIe x4 (Gen 3) 1 x M.2 2280 M Key (PCIe Gen3 x 4) 1 x M.2 2230 E Key (USB/PCIe) 2 PCIe x8 (x1 signal)	Electromagnetic compatibility (EMC)	EN 55022 Class A EN 55024 Electrostatic discharge immunity test (EN61000-4-2) Enclosure port ±4kV Contact, applied to enclosure port ±8kV Air, applied to enclosure port Radiated, radio-frequency, electromagnetic field immunity test (EN61000-4-3) Enclosure port 80-1000MHz, 10 V/m (RMS, no modulation) 80% Modulation with 1kHz Sine wave Electrical fast transient/burst immunity test (EN61000-4-4) Power port inc. protective earth Severity ±0.5kV Immunity to conducted disturbances induced by radio frequency fields (EN61000-4-6) Power port inc. protective earth via CDN M3 0.15-80MHz, 10 V/m (no modulation) 80% Modulation with 1kHz Sine wave, applied via CDN Amplicon own a fully equipped EMC facility and can provide many additional tests to meet your requirements.
Supported O/S	Windows 10/Linux	Certifications	CE
External Interfaces	4 x USB 3.1 2 x USB2.0 (Front) 2 x RJ45 LAN 2 x RS-232 2 x RS-232/422/485 2 x DP++ 1 x VGA (Optional)		
LED and switches	Power (PC on LED) Hard disk access LED ATX system control switch		

Rear I/O Plate

